

TOSHIBA

INSTALLATION MANUAL
MANUEL D'INSTALLATION
INSTALLATIONS-HANDBUCH
MANUALE DI INSTALLAZIONE
MANUAL DE INSTALACIÓN
MANUAL DE INSTALAÇÃO
INSTALLATIEHANDLEIDING
ΕΓΧΕΙΡΙΔΙΟ ΕΓΚΑΤΑΣΤΑΣΗΣ

AIR CONDITIONER (SPLIT TYPE)
CLIMATISEUR (TYPE SPLIT)
KLIMAGERÄT (SPLIT-TYP)
CONDIZIONATORE D'ARIA (TIPO SPLIT)
AIRE ACONDICIONADO (TIPO SPLIT)
AR CONDICIONADO (TIPO SPLIT)
AIRCONDITIONER (GESPLITST TYPE)
ΚΛΙΜΑΤΙΣΤΙΚΟ (ΤΥΠΟΣ SPLIT)

<4-Way Air Discharge Cassette Type>/<Type cassette à 4 voies de soufflage>
<4-Wege-Belüftungskassette>/<Tipo a cassetta con scarico d'aria a 4 vie>
<Modelo de casete de distribución de aire de 4 vías>/<Descarga de ar tipo casete de 4 vías>
<Model voor inbouw in plafond met 4 uitblaasopeningen>/<Εκροή αέρα 4-Διευθύνσεων Τύπου Κασέτας>

Heat Pump Model/Modèle à thermopompe
Geräte mit Heizung/Modello con pompa di riscaldamento
Modelo con bomba de calor/Modelo de bomba térmica
Model met warmtepomp/Μοντέλο με Αντλία Θερμότητας

Indoor Unit/Unité intérieure
Raumeinheit/Unità interna
Unidad interior/Unidade interior
Binnenunit/Εσωτερική μονάδα

Outdoor Unit/Unité extérieure
Außengerät/Unità esterna
Unidad exterior/Unidade exterior
Buitenunit/Εξωτερική μονάδα



RAV-SM562UT-E
RAV-SM802UT-E
RAV-SM1102UT-E
RAV-SM1402UT-E
RAV-SP1102UT-E

RAV-SM562AT-E SP562AT-E
RAV-SM802AT-E SP802AT-E
RAV-SM1102AT-E SP1102AT-E
RAV-SM1402AT-E SP1402AT-E

Please read this Installation Manual carefully before installing the Air Conditioner.

- This Manual describes the installation method of the indoor unit.
- For installation of the outdoor unit, follow the Installation Manual attached to the outdoor unit.

Veuillez lire attentivement ce Manuel d'installation avant d'installer le climatiseur.

- Ce manuel décrit la procédure d'installation de l'unité intérieure.
- Pour installer l'unité extérieure, reportez-vous au Manuel d'installation fourni avec l'unité extérieure.

Bitte lesen Sie dieses Handbuch sorgfältig, bevor Sie mit der Installation des Klimagerätes beginnen.

- In diesem Handbuch wird die Installation der Raumeinheit beschrieben.
- Um die Außeneinheit zu installieren, folgen Sie den Anweisungen in dem Handbuch, das der Außeneinheit beiliegt.

Prima di installare il condizionatore d'aria, leggere con attenzione questo manuale d'installazione.

- Questo manuale descrive il metodo d'installazione dell'unità interna.
- Per l'installazione dell'unità esterna, fare riferimento al manuale d'installazione fornito insieme all'unità esterna.

Lea atentamente este Manual de instalación antes de proceder a la instalación del aparato de aire acondicionado.

- Este manual describe el método de instalación de la unidad interior.
- Para la instalación de la unidad exterior, consulte el Manual de instalación que acompaña a la unidad exterior.

Leia atentamente o presente Manual de Instalação antes de instalar o Ar Condicionado.

- O presente manual descreve o método de instalar a unidade interior.
- Para a instalação de uma unidade exterior, siga o Manual de Instalação que acompanha a unidade exterior.

Lees deze installatiehandleiding zorgvuldig door voordat u de airconditioner gaat installeren.

- Deze installatiemethode beschrijft de installatiemethode van de binnenunit.
- Zie voor de installatie van de buitenunit, de installatiehandleiding bij de buitenunit.

Παρακαλώ διαβάστε προσεκτικά το Εγχειρίδιο Εγκατάστασης πριν από την εγκατάσταση του Κλιματιστικού.

- Το παρόν Εγχειρίδιο περιγράφει τη μέθοδο εγκατάστασης της εσωτερικής μονάδας.
- Για την εγκατάσταση της εξωτερικής μονάδας, ακολουθήστε το Εγχειρίδιο Εγκατάστασης που συνοδεύει την εξωτερική μονάδα.

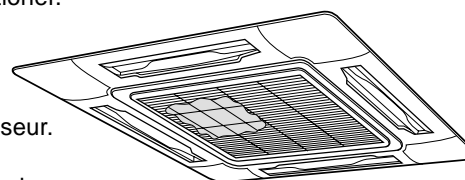

ADOPTION OF NEW REFRIGERANT

This Air Conditioner is a new type which adopts a new refrigerant HFC (R410A) instead of the conventional refrigerant R22 in order to prevent destruction of the ozone layer.

UTILISATION DU NOUVEAU REFRIGERANT

Ce climatiseur est d'un type inédit qui utilise le nouveau réfrigérant HFC (R410A) au lieu du réfrigérant traditionnel R22, afin d'éviter la destruction de la couche d'ozone.

EINFÜHRUNG EINES NEUEN KÜHLMITTELS

Dies ist ein neuartiges Klimagerät. Anstatt des herkömmlichen Kühlmittels R22 verwendet es das neue ozonschichtschonende HFC Kühlmittel R410A.

ADOZIONE DI UN NUOVO REFRIGERANTE

Questo condizionatore d'aria è di un tipo nuovo che adotta un nuovo refrigerante HFC (R410A) al posto del refrigerante convenzionale R22, per prevenire la distruzione dello strato di ozono dell'atmosfera terrestre.

ADOPCIÓN DE NUEVO REFRIGERANTE

Este aparato de aire acondicionado es un modelo reciente que incorpora el nuevo refrigerante HFC (R410A) en lugar del refrigerante convencional R22 para así evitar daños en la capa de ozono.

ADOPÇÃO DO NOVO REFRIGERANTE

Este ar condicionado é um modelo novo que adota um novo refrigerante HFC (R410A) em vez do refrigerante convencional R22 para evitar a destruição da camada de ozono.

TOEPASSING VAN EEN NIEUW KOELMIDDEL

Deze airconditioner is een nieuwe type dat werkt met een nieuw koelmiddel HFC (R410A) in plaats van met het conventionele koelmiddel R22, als bijdrage om de aantasting van de ozonlaag te reduceren.

ΥΙΟΘΕΤΗΣΗ ΝΕΟΥ ΨΥΚΤΙΚΟΥ

Το παρόν Κλιματιστικό είναι νέος τύπος που υιοθετεί νέο ψυκτικό HFC (R410A) στη θέση του συμβατικού ψυκτικού R22 προκειμένου να βοηθήσει στην προστασία του όζοντος.

CONTENTS

Accessory parts and Parts to be procured locally	1	5	ELECTRICAL WORK	13
1 PRECAUTIONS FOR SAFETY	2	6	TEST RUN	16
2 SELECTION OF INSTALLATION PLACE	4	7	APPLICABLE CONTROLS	18
3 DRAIN PIPING WORK	9	8	TROUBLESHOOTING	22
4 REFRIGERANT PIPING AND EVACUATING	11	9	MAINTENANCE	23

SOMMAIRE

Pièces accessoires et pièces non fournies	24	5	INSTALLATION ELECTRIQUE	36
1 MESURES DE SECURITE	25	6	ESSAI DE FONCTIONNEMENT	39
2 SELECTION DU LIEU D'INSTALLATION	27	7	COMMANDES UTILISABLES	41
3 INSTALLATION DES TUYAUX D'EVACUATION	32	8	DEPANNAGE	45
4 TUYAUTERIE DE FRIGORIGÈNE ET ÉVACUATION	34	9	ENTRETIEN	46

INHALT

Zubehör und bauseits bereitzustellende Teile	47	5	ELEKTROINSTALLATION	59
1 SICHERHEITSVORKEHRUNGEN	48	6	TESTLAUF	62
2 AUSWAHL DES AUFSTELLUNGORTES	50	7	STEUERUNGSMÖGLICHKEITEN	64
3 INSTALLATION DES ABLAUFROHRS	55	8	FEHLERBESEITIGUNG	68
4 KÜHLMITTELLEITUNGSSYSTEM UND ENTLÜFTUNG	57	9	WARTUNG	69

INDICE

Accessori e parti da acquistare sul posto	70	5	ESECUZIONE DEI COLLEGAMENTI ELETTRICI	82
1 PRECAUZIONI PER LA SICUREZZA	71	6	FUNZIONAMENTO DI PROVA	85
2 SCELTA DEL POSTO D'INSTALLAZIONE	73	7	COMANDI APPLICABILI	87
3 LAVORO PER TUBAZIONE DI SCARICO	78	8	GUIDA PER I PROBLEMI DI FUNZIONAMENTO	91
4 TUBAZIONI DEL REFRIGERANTE E SCARICO	80	9	MANUTENZIONE	92

CONTENIDO

Componentes accesorios y componentes de obtención local ...	93	5	TRABAJOS EN EL SISTEMA ELÉCTRICO	105
1 PRECAUCIONES PARA SU SEGURIDAD	94	6	PRUEBA DE FUNCIONAMIENTO	108
2 SELECCIÓN DEL LUGAR DE INSTALACIÓN	96	7	CONTROLES APLICABLES	110
3 TRABAJOS DE CANALIZACIÓN DE DESAGÜE	101	8	SOLUCIÓN DE PROBLEMAS	114
4 TUBOS DE REFRIGERANTE Y EVACUACIÓN	103	9	MANTENIMIENTO	115

ÍNDICE

Acessórios e peças adquiridas localmente	116	5	LIGAÇÕES ELÉCTRICAS	128
1 PRECAUÇÕES DE SEGURANÇA	117	6	ENSAIO DE FUNCIONAMENTO	131
2 SELECÇÃO DO LOCAL DE INSTALAÇÃO	119	7	CONTROLOS APLICÁVEIS	133
3 INSTALAÇÃO DA TUBAGEM DE DRENAGEM	124	8	RESOLUÇÃO DE PROBLEMAS	137
4 TUBAGEM DE REFRIGERANTE E EVACUAÇÃO	126	9	MANUTENÇÃO	138

INHOUD

Accessoires en niet meegeleverde onderdelen	139	5	ELEKTRISCH GEDEELTE	151
1 VOORZORGSMAATREGELEN VOOR UW VEILIGHEID	140	6	WERKINGSTEST	154
2 KEUZE VAN DE LOCATIE VOOR DE INSTALLATIE	142	7	BEDIENINGSELEMENTEN	156
3 AFVOERLEIDINGEN	147	8	STORINGEN VERHELPEN	160
4 KOELMIDDELLEIDINGEN EN ONTLUCHTEN	149	9	ONDERHOUD	161

ΠΕΡΙΕΧΟΜΕΝΑ

Παρελκόμενα ανταλλακτικά και Εξαρτήματα από την τοπική αγορά .	162	5	ΗΛΕΚΤΡΟΛΟΓΙΚΑ	174
1 ΠΡΟΦΥΛΑΞΕΙΣ ΑΣΦΑΛΕΙΑΣ	163	6	ΔΟΚΙΜΗ ΛΕΙΤΟΥΡΓΙΑΣ	177
2 ΕΠΙΛΟΓΗ ΤΟΥ ΧΩΡΟΥ ΕΓΚΑΤΑΣΤΑΣΗΣ	165	7	ΕΦΑΡΜΟΣΙΜΟΙ ΕΛΕΓΧΟΙ	179
3 ΕΓΚΑΤΑΣΤΑΣΗ ΣΩΛΗΝΩΣΕΩΝ ΑΠΟΣΤΡΑΓΓΙΣΗΣ	170	8	ΑΝΤΙΜΕΤΩΠΙΣΗ ΠΡΟΒΛΗΜΑΤΩΝ	183
4 ΣΩΛΗΝΩΣΕΙΣ ΨΥΞΗΣ ΚΑΙ ΑΠΟΣΤΡΑΓΓΙΣΗΣ	172	9	ΣΥΝΤΗΡΗΣΗ	184

ENGLISH

FRANCAIS

DEUTSCH

ITALIANO

ESPAÑOL





PORTUGUÊS





NEDERLANDS

ΕΛΛΗΝΙΚΑ

Accessory parts and Parts to be procured locally

□ Accessory parts

Part name	Q'ty	Shape	Usage
Installation Manual	1	This manual	(Be sure to hand over to customers)
Heat insulating pipe	2		For heat insulation of pipe connecting section
Installation pattern	1		For confirmation of ceiling opening and main unit position
Installation gauge	2		For positioning of ceiling position (united with installation pattern)
Pattern fixing screw	4	M5 x 16L	For attach the installation pattern
Heat insulator	1		For heat insulation of drain connecting section

Part name	Q'ty	Shape	Usage
Washer	8		For hanging-down unit
Hose band	1		For connecting drain pipe
Flexible hose	1		For adjusting core-out of drain pipe
Heat insulator	1		For sealing of wire connecting port
Owner's Manual	1		(Be sure to hand over to customers)

<Separate sold parts>

Part name	Q'ty	Shape	Usage
Standard wired remote controller	1		Model RBC-AMT31E

Part name	Q'ty	Shape	Usage
Ceiling panel	1		Model RBC-U21PG (W)-E2

□ Parts to be procured locally

<p>Connecting pipe (Liquid side) (6.4mm (diam.), Nominal (diam.) 1/4" thick 0.8mm) RAV-SM562UT-E</p> <p>(9.5mm (diam.), Nominal (diam.) 3/8" thick 0.8mm) RAV-SM802UT-E, RAV-SM1102UT-E, RAV-SM1402UT-E, RAV-SP1102UT-E</p>
<p>Connecting pipe (Gas side) (12.7mm (diam.), Nominal (diam.) 1/2" thick 0.8mm) RAV-SM562UT-E</p> <p>(15.9mm (diam.), Nominal (diam.) 5/8" thick 1.0mm) RAV-SM802UT-E, RAV-SM1102UT-E, RAV-SM1402UT-E, RAV-SP1102UT-E</p>
<p>Power supply cord 2.5mm² (H07RN-F or 245 IEC66) or 3.5mm² (AWG-12)</p>

<p>Connecting cable (indoor and outdoor cable) H07RN-F or 245 IEC66 (1.5mm² or more)</p>
<p>Thermal insulation for refrigerant pipe (10mm or more, thermal insulating foam polyethylene)</p>
<p>Thermal insulation for drain pipe (10mm or more, foam polyethylene)</p>
<p>Drain pipe (Outer 26mm (diam.))</p>
<p>Tapes</p>
<p>Grounding cable (2.0mm (diam.) or more)</p>

1 PRECAUTIONS FOR SAFETY

- Ensure that all Local, National and International regulations are satisfied.
- Read this "PRECAUTIONS FOR SAFETY" carefully before Installation.
- The precautions described below include the important items regarding safety. Observe them without fail.
- After the installation work, perform a trial operation to check for any problem.
Follow the Owner's Manual to explain how to use and maintain the unit to the customer.
- Turn off the main power supply switch (or breaker) before the unit maintenance.
- Ask the customer to keep the Installation Manual together with the Owner's Manual.

CAUTION

New Refrigerant Air Conditioner Installation

- **THIS AIR CONDITIONER ADOPTS THE NEW HFC REFRIGERANT (R410A) WHICH DOES NOT DESTROY OZONE LAYER.**

The characteristics of R410A refrigerant are ; easy to absorb water, oxidizing membrane or oil, and its pressure is approx. 1.6 times higher than that of refrigerant R22. Accompanied with the new refrigerant, refrigerating oil has also been changed. Therefore, during installation work, be sure that water, dust, former refrigerant, or refrigerating oil does not enter the refrigerating cycle.

To prevent charging an incorrect refrigerant and refrigerating oil, the sizes of connecting sections of charging port of the main unit and installation tools are changed from those for the conventional refrigerant.

Accordingly the exclusive tools are required for the new refrigerant (R410A).

For connecting pipes, use new and clean piping designed for R410A, and please care so that water or dust does not enter. Moreover, do not use the existing piping because there are problems with pressure-resistance force and impurity in it.

CAUTION

To Disconnect the Appliance from Main Power Supply.

This appliance must be connected to the main power supply by means of a switch with a contact separation of at least 3 mm.

The installation fuse (25A D type ) must be used for the power supply line of this conditioner.

WARNINGS

- **Ask an authorized dealer or qualified installation professional to install/maintain the air conditioner.**
Inappropriate installation may result in water leakage, electric shock or fire.
- **Turn off the main power supply switch or breaker before attempting any electrical work.**
Make sure all power switches are off. Failure to do so may cause electric shock.
- **Connect the connecting cable correctly.**
If the connecting cable is connected in a wrong way, electric parts may be damaged.
- **When moving the air conditioner for the installation into another place, be very careful not to enter any gaseous matter other than the specified refrigerant into the refrigeration cycle.**
If air or any other gas is mixed in the refrigerant, the gas pressure in the refrigeration cycle becomes abnormally high and it resultingly causes pipe burst and injuries on persons.
- **Do not modify this unit by removing any of the safety guards or by by-passing any of the safety interlock switches.**
- **Exposure of unit to water or other moisture before installation may cause a short-circuit of electrical parts.**
Do not store it in a wet basement or expose to rain or water.

1 PRECAUTIONS FOR SAFETY

- **After unpacking the unit, examine it carefully if there are possible damage.**
- **Do not install in a place that might increase the vibration of the unit.**
- **To avoid personal injury (with sharp edges), be careful when handling parts.**
- **Perform installation work properly according to the Installation Manual.**
Inappropriate installation may result in water leakage, electric shock or fire.
- **When the air conditioner is installed in a small room, provide appropriate measures to ensure that the concentration of refrigerant leakage occur in the room does not exceed the critical level.**
- **Install the air conditioner securely in a location where the base can sustain the weight adequately.**
- **Perform the specified installation work to guard against an earthquake.**
If the air conditioner is not installed appropriately, accidents may occur due to the falling unit.
- **If refrigerant gas has leaked during the installation work, ventilate the room immediately.**
If the leaked refrigerant gas comes in contact with fire, noxious gas may generate.
- **After the installation work, confirm that refrigerant gas does not leak.**
If refrigerant gas leaks into the room and flows near a fire source, such as a cooking range, noxious gas might generate.
- **Electrical work must be performed by a qualified electrician in accordance with the Installation Manual. Make sure the air conditioner uses an exclusive power supply.**
An insufficient power supply capacity or inappropriate installation may cause fire.
- **Use the specified cables for wiring connect the terminals securely fix. To prevent external forces applied to the terminals from affecting the terminals.**
- **Conform to the regulations of the local electric company when wiring the power supply.**
Inappropriate grounding may cause electric shock.
- **Do not install the air conditioner in a location subject to a risk of exposure to a combustible gas.**
If a combustible gas leaks, and stays around the unit, a fire may occur.

2 SELECTION OF INSTALLATION PLACE

⚠ WARNING

- **Install the air conditioner at enough strong place to withstand the weight of the unit.**
If the strength is not enough, the unit may fall down resulting in injury.
- **Install the air conditioner at a height 2.5m or more from the floor.**
If you insert your hands or others directly into the unit while the air conditioner operates, it is dangerous because you may contact with revolving fan or active electricity.

⚠ CAUTION

- **Do not install the air conditioner in a location subject to a risk of exposure to a combustible gas.**
If a combustible gas leaks and stays around the unit, a fire may occur.

Upon approval of the customer, install the air conditioner in a place that satisfies the following conditions.

- Place where the unit can be installed horizontally.
- Place where a sufficient servicing space can be ensured for safety maintenance and check.
- Place where drained water will not cause any problem.

Avoid installing in the following places.

- Place exposed to air with high salt content (seaside area), or place exposed to large quantities of sulfide gas (hot spring). (Should the unit be used in these places, special protective measures are needed.)
- Place exposed to oil, vapor, oil smoke or corrosive gas.
- Place where organic solvent is used nearby.
- Place close to a machine generating high frequency.
- Place where the discharged air blows directly into the window of the neighboring house. (For outdoor unit)
- Place where noise of the outdoor unit is easily transmitted.
(When installing the air conditioner on the boundary with the neighbor, pay due attention to the level of noise.)
- Place with poor ventilation. (Before air ducting work, check whether value of air volume, static pressure and duct resistance are correct.)

Installation space

Secure the specified space in the figure for installation and servicing.

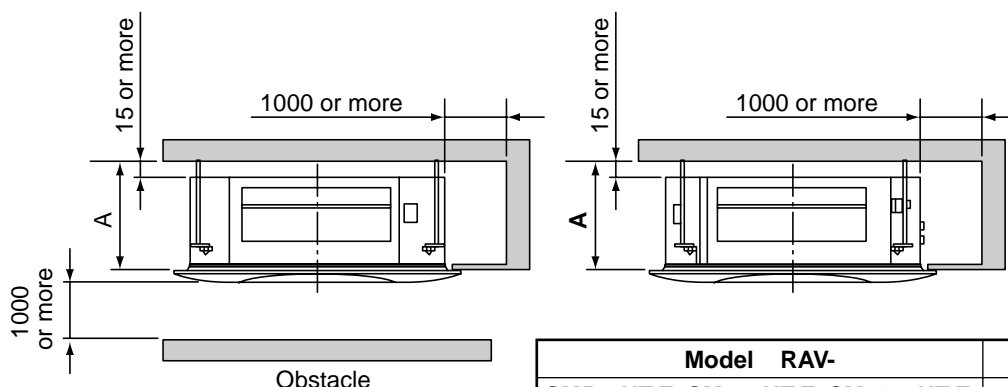

Model RAV-	A mm
SM562UT-E, SM802UT-E, SM1102UT-E	271 or more
SM1402UT-E, SP1102UT-E	334 or more

2 SELECTION OF INSTALLATION PLACE

Selection of installation place

In case of continued operation of the indoor unit under high-humidity conditions as described below, dew may condense and water may drop.

Especially, high-humidity atmosphere (dew point temperature : 23°C or more) may generate dew inside the ceiling.

1. Unit is installed inside the ceiling with slated roof.
2. Unit is installed at a location using inside of the ceiling as fresh air take-in path.
3. Kitchen

If installing a unit at such place, put insulating material (glass wool, etc.) additionally on all the positions of the indoor unit which come to contact with high-humidity atmosphere.

Advice

Set a service check opening panel at right side of the unit (size: 450 × 450mm or more) for piping, maintenance, and servicing.

Ceiling height

Model RAV-	Possible installed ceiling height
SM562, SM802UT-E	Up to 3.8 m
SM1102, SM1402, SP1102UT-E	Up to 4.3 m

When the height of the ceiling exceeds the distance of the item Standard/4-way in Table below, the hot air is difficult to reach the floor. Therefore, it is necessary to change the setup value of the high ceiling switch or discharge direction.

REQUIREMENT

- When using the air conditioner with 2-way discharge system with the standard setting (at a shipment), it may stop abnormally in heating. Therefore, change the setting switch according to the number of discharge direction and the ceiling height.
- When using the air conditioner with 2-way/3-way discharge system, a strong wind blows directly if the ceiling height is lower than the standard. Therefore, change the setting switch according to height of the ceiling.
- When using the high ceiling (1) or (2) with 4-way discharge system, the draft is apt to be felt due to drop of the discharge temperature.

Discharge direction

As shown in the following figure, No. of discharge directions can be selected according to the shape of rooms and installation position.

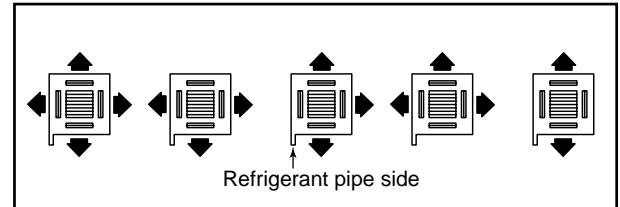

As shown in the following figure direction are not acceptable.

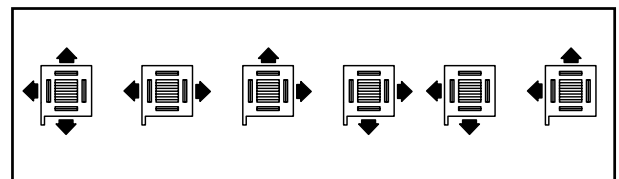

- To change discharge direction, use a shielding plate.
- When attaching a shielding plate, remove the ceiling panel and insert the shielding plate into the discharge port as shown in the figure below.

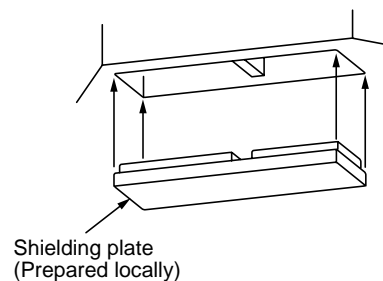

WARNING

Install the air conditioner certainly to sufficiently withstand the weight.
If the strength is insufficient, the unit may fall down resulting in human injury.
Perform a specified installation work to guard against an earthquake.
An incomplete installation can cause accidents by the units falling and dropping.

Height list of ceiling possible to be installed

(Unit : m)

Model RAV-	SM562UT-E			SM802UT-E			SM1102, SM1402, SP1102UT-E			High ceiling setup
	No. of discharge direction	4-way	3-way	2-way	4-way	3-way	2-way	4-way	3-way	
Standard (at shipment)	2.8	3.2	3.5	3.0	3.3	3.6	3.6	3.9	4.2	Set data
High ceiling (1)	3.2	3.5	3.8	3.3	3.5	3.8	3.9	4.1	4.3	0001
High ceiling (2)	3.5	3.8	—	3.6	3.8	—	4.2	4.3	—	0003

External view

REQUIREMENT

Strictly comply with the following rules to prevent damage of the indoor units and human injury.

- Do not put a heavy article on the indoor unit. (Even units are packaged)
- Carry in the indoor unit as it is packaged if possible. If carrying in the indoor unit unpacked by necessity, be sure to use buffering cloth, etc. to not damage the unit.
- To move the indoor unit, hold the hooking metals (4 positions) only. Do not apply force to the other parts (refrigerant pipe, drain pan, foamed parts, or resin parts, etc.).
- Carry the package by two or more persons, and do not bundle it with PP band at positions other than specified.

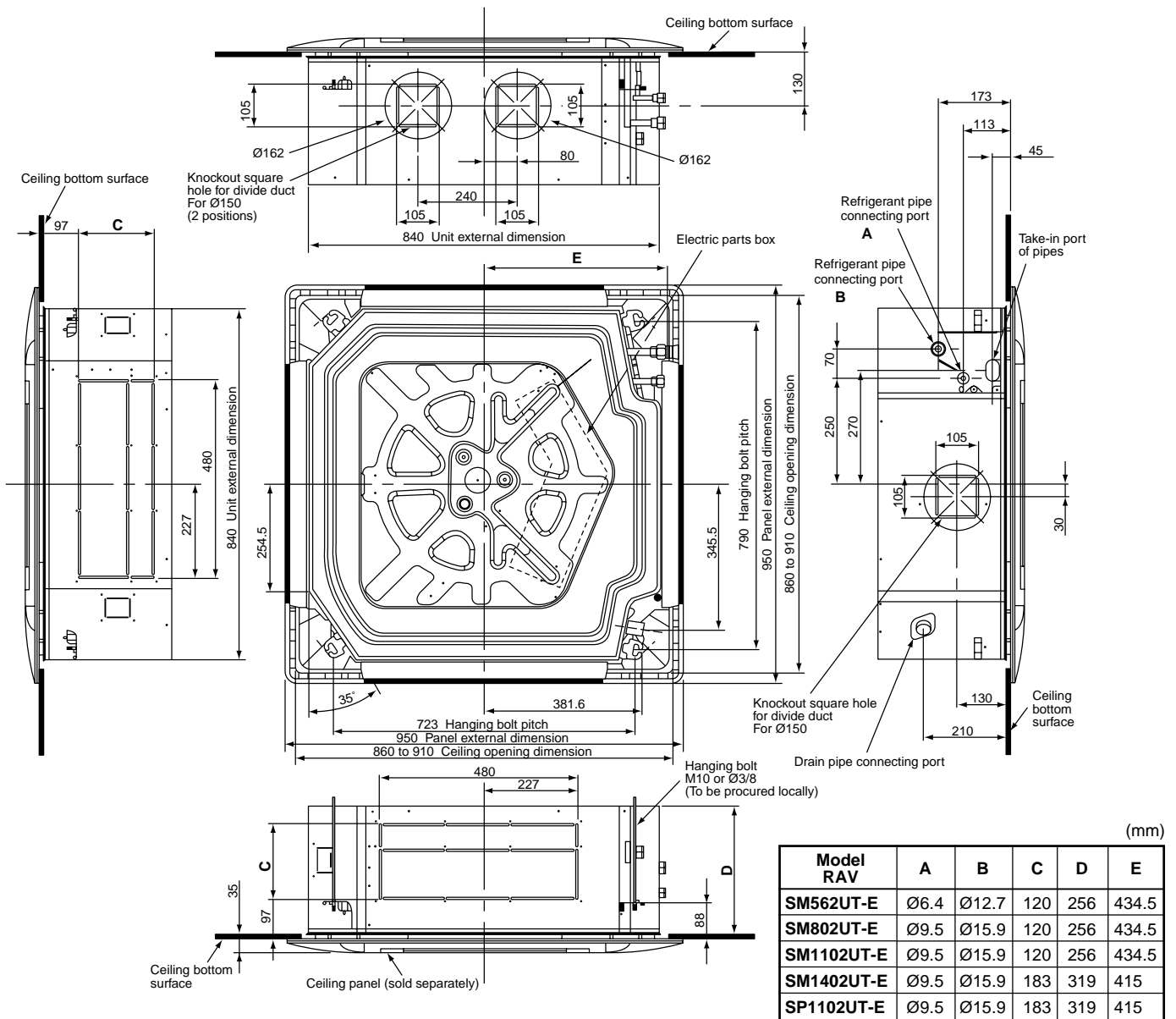

Considering pipe/wire connecting work inside the ceiling after the indoor unit has been hanged, select an installation place and determine piping direction.

- If the ceiling has already been set before hanging the main unit, prepare refrigerant pipe, drain pipe, indoor connecting wire, remote controller cord, etc. up to the place where pipe and wire can be connected.
- Check the size of the indoor unit, and match the indoor unit size, with ceiling opening size and that position using the attached installation pattern.
(Attach the pattern to the lower side of indoor unit with attached four screws M5 x 16L.)

2 SELECTION OF INSTALLATION PLACE

Opening a ceiling and installation of hanging bolts

<Treatment of ceiling>

The ceiling differs according to structure of building. For details, consult your constructor or interior finish contractor. In the process after the ceiling board has been removed, it is important to reinforce ceiling foundation (frame) and to keep horizontal level of installed ceiling correctly in order to prevent vibration of ceiling board.

- (1) Cut and remove the ceiling foundation.
- (2) Reinforce the cut surface of ceiling foundation, and add ceiling foundation for fixing the end of ceiling board.

<Installation of hanging bolt>

Use M10 hanging bolts (4 pcs, to be local procure). Matching to the existing structure, set pitch according to size in the unit external view as shown below.

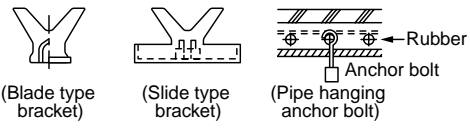
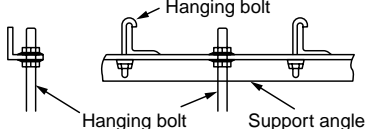
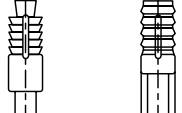
New concrete slab	Steel frame structure	Existing concrete slab
Install the bolts with insert brackets or anchor bolts. 	Use existing angles or install new support angles. 	Use a hole-in anchors, hole-in plugs, or a hole-in bolts. 

Installation of ceiling opening and hanging bolt

Adjust nut position (lower side) so that clearance between the attached washer (lower side) and ceiling board is 88mm.

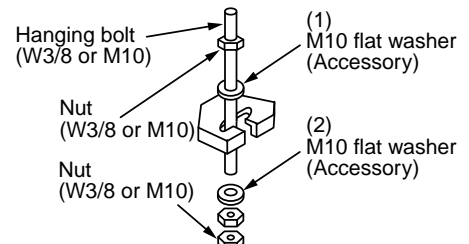
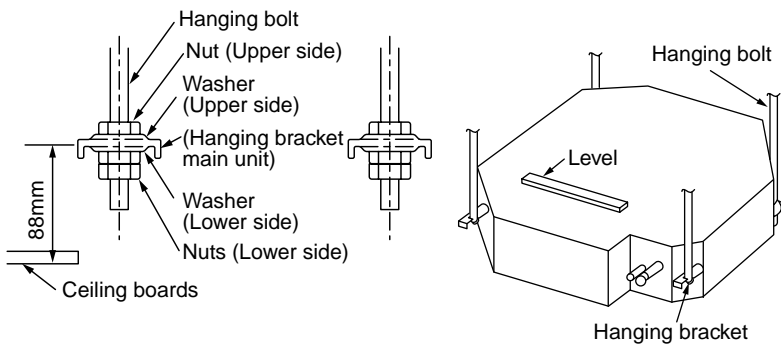

- (1) Required those other than M10 flat washer at site.
- (2) To prevent falling-off of bolt (safety), be sure to set it just under the hanging bracket as shown in the figure.

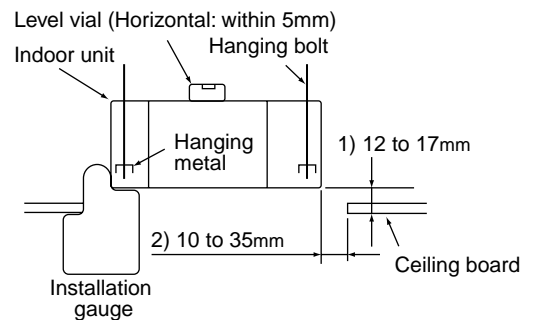

- Hang up the main unit by hanging the nut of hanging bolt to T groove of hanging bracket of the main unit.
- Using the level vial, etc., set the horizontal level of the main unit within 5mm.
- Using the installation gauge, check and adjust the positional relation between the main unit and ceiling opening hole, and hanging-up height of the main unit. (Direction to be used is indicated on the installation gauge.)
 - 1) Check lower side of the indoor unit locates at position (12 to 17) mm higher than the lower surface of the ceiling board. (4 corners)
 - 2) Check clearance between side of the indoor unit and the ceiling board is 10 to 35mm. (Common to 4 corners)

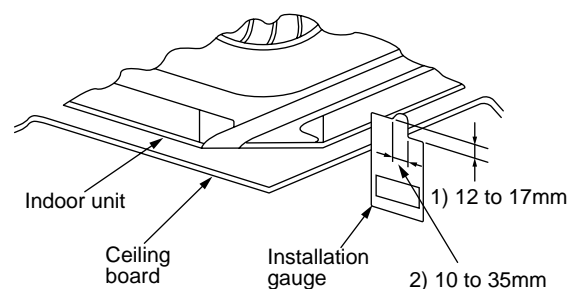

REQUIREMENT

Before installation of the indoor unit, be sure to remove the cushion for transportation between the fan and the bell mouth. Running the unit without removing the cushion may damage the fan motor.

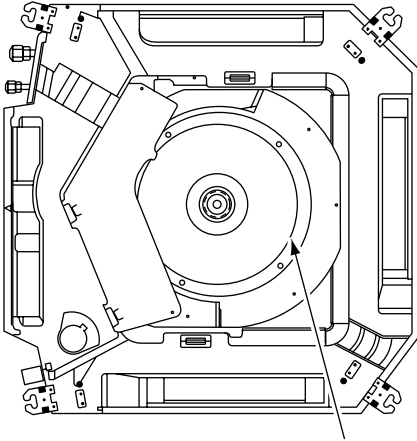

Be sure to remove the cushion for transportation between the fan and the bell mouth.

Installation of ceiling panel (Sold separately)

Install the ceiling panel according to Installation Manual attached with it after piping/wiring work has completed.

Check that installation of indoor unit and ceiling opening part is correct, and then install it.

REQUIREMENT

Joint the connecting sections of ceiling panel, ceiling surface, ceiling panel and indoor unit closely.

Any gap between them will cause air leakage and this generate condensation or water leakage.

Installation of remote controller (Sold separately)

For installation of the wired remote controller, follow the Installation Manual attached with the remote controller.

- Pull out the remote controller cord together with the refrigerant pipe or drain pipe.
Be sure to pass the remote controller cord through upper side of the refrigerant pipe and drain pipe.
- Do not leave the remote controller at a place exposed to the direct sunlight and near a stove.
- Operate the remote controller, confirm that the indoor unit receives a signal surely, and then install it. (Wireless type)
- Keep 1m or more from the devices such as television, stereo, etc.
(Disturbance of image or noise may generate.)
(Wireless type)

In case of wireless type

The sensor of indoor unit with wireless remote controller can receive a signal by distance within approx. 7m. Based upon it, determine a place where the remote controller is operated and the installation place.

- To prevent a malfunction, select a place where is not influenced by a fluorescent light or direct sunlight.
- Two or more (Up to 6 units) indoor units with wireless type remote controller can be installed in the same room.

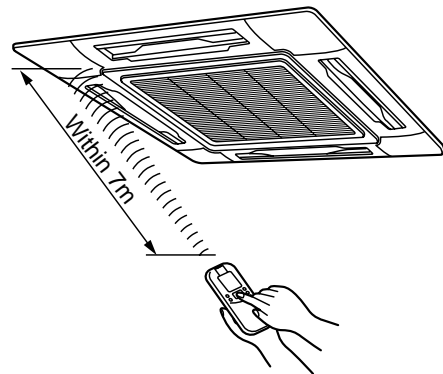

3 DRAIN PIPING WORK

CAUTION

- Following the Installation Manual, perform the drain piping work so that water is properly drained, and apply a heat insulation so as not to cause a dew. Inappropriate piping work may result in water leakage in the room and wet of furniture.

Piping/Heat insulating material

Require the following materials for piping and heat insulating at site.

Piping	Hard vinyl chloride pipe VP25 (Outer dia. : Ø32mm)
Heat insulator	Foam polyethylene : Thickness 10mm or more

REQUIREMENT

- Be sure to perform heat insulation of the drain pipes of the indoor unit.
- Never forget to perform heat insulation of the connecting part with the indoor unit. An incomplete heat insulation causes dewing.
- Set the drain pipe with downward slope (1/100 or more), and do not make swelling or trap on the piping. It may cause an abnormal sound.
- For length of the traversing drain pipe, restrict to 20m or less. In case of a long pipe, provide support brackets with interval of 1.5 to 2m in order to prevent waving.

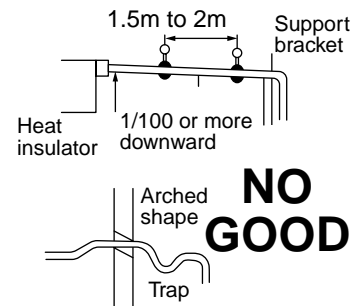

- Set the collective piping as shown in the right figure.
- Be sure not to apply force to the connecting part of the drain pipe.
- The hard vinyl-chloride pipe cannot be directly connected to the drain pipe connecting port of the indoor unit. For connection with the drain pipe connecting port, be sure to use/fix the attached flexible hose with the hose band, otherwise a damage or water leak is caused on the drain pipe connecting port.

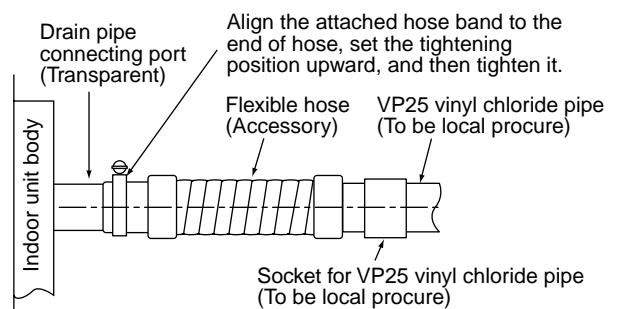
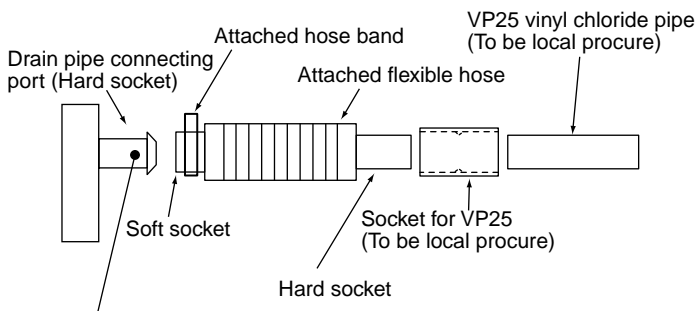
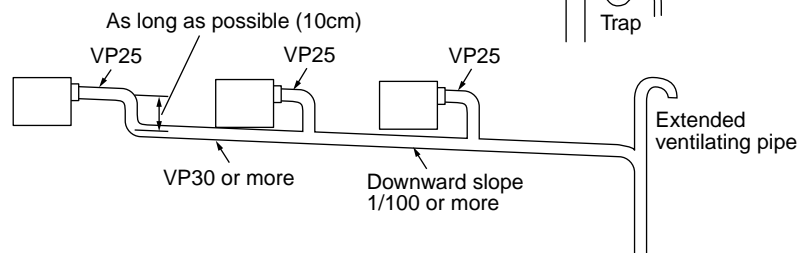

Adhesive inhibited :

Use the attached flexible hose and hose band for connecting the drain hose to the clear drain socket. If applying the adhesive, socket will be damaged and cause water leakage.

Flexible hose

Use the attached flexible hose to adjust core discrepancy of the hard vinyl chloride pipe or to adjust the angle.

- Do not use the flexible hose as stretched, or do not deform it more extent than that in the following figure.
- Be sure to fix the soft end of the flexible hose with the attached hose band.
- Use the flexible hose on a horizontal level.

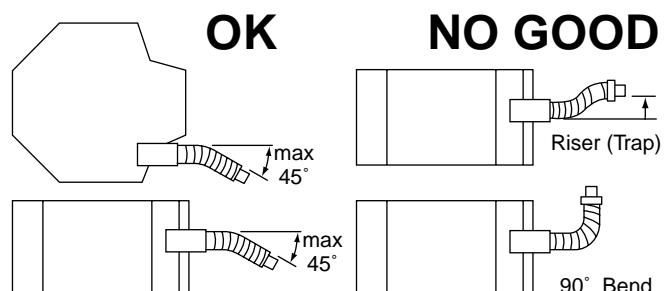

Connection procedure

Connect a socket and a hard vinyl chloride pipe.

- Using adhesive agent for vinyl chloride pipe, connect the drain pipes certainly so that water does not leak.
- It takes approx. 10 hours to dry and harden the adhesive agent. During this period, do not apply force to the connecting part with the drain pipe.

Perform heat insulating.

- As shown in the figure, cover the flexible hose and hose band with the attached heat insulator up to the bottom of the indoor unit without gap.

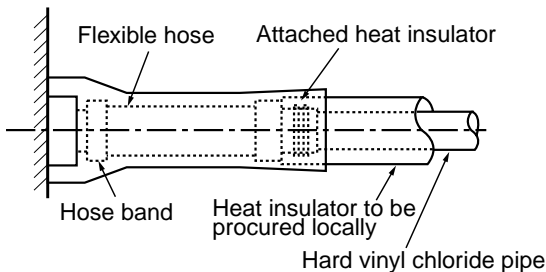

Drain up

When a downward grading cannot be secured on the drain pipe, drain-up up to 640mm is possible.

Set downward grading immediately after raising up vertically.

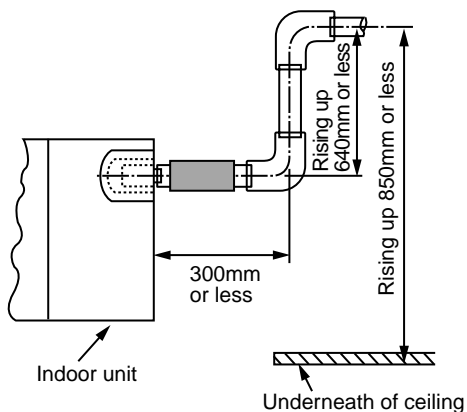

Check the draining

In the test run, check that water drain is properly performed and water does not leak from the connecting part of the pipes.

Be sure to check draining also when installed in heating period.

Using a pitcher or hose, pour water (1500 to 2000cc) into the discharge port before installation of the ceiling panel.

Pour water gradually so that water does not spread on the motor of the drain pump.

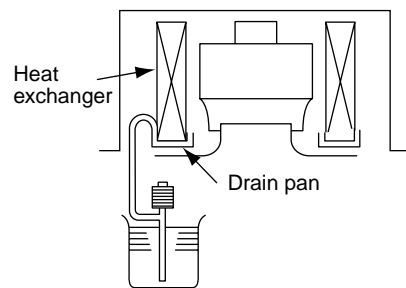

- After the electric work has finished, pour water during COOL mode operation.
- If the electric work has not yet finished, pull out the float switch connector (CN34 : Red) from the electric parts box, and check draining by plugging the single phase 220–240V power to the terminal blocks ① and ②.

If doing so, the drain pump motor operates.

- Test water drain while checking the operation sound of the drain pump motor. (If the operation sound changes from continuous sound to intermittent sound, water is normally drained.)

After the check, the drain pump motor runs, connecting the float switch connector.

(In case of check by pulling out the float switch connector, be sure to return the connector to the original position.)

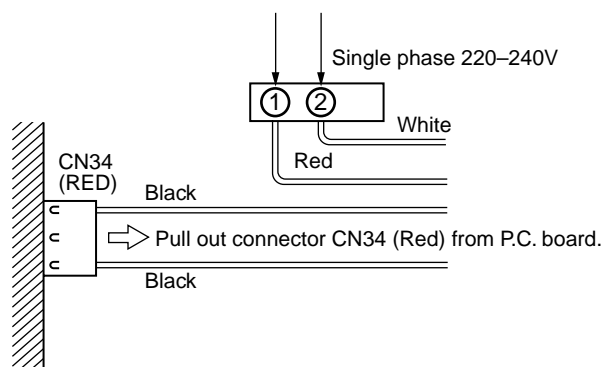

4 REFRIGERANT PIPING AND EVACUATING

Refrigerant Piping

- If the outdoor units are to be mounted on a wall, make sure that the supporting platform is sufficiently strong. The platform should be designed and manufactured to maintain its strength over a long period of time, and sufficient consideration should be given to ensuring that the outdoor unit will not fall.
- Use copper pipe with 0.8 mm or more thickness. (In case pipe size is $\varnothing 15.9$, with 1.0mm or more.)
- Flare nut and flare works are also different from those of the conventional refrigerant. Take out the flare nut attached to the main unit of the air conditioner, and use it.

CAUTION

IMPORTANT 4 POINTS FOR PIPING WORK

- Remove dust and moisture from the inside of the connecting pipes.
- Tight connection (between pipes and unit)
- Evacuate the air in the connecting pipes using VACUUM PUMP.
- Check the gas leakage. (Connected points)

Permissible Piping Length and Heat

They vary according to the outdoor unit. For details, refer to the Installation Manual attached to the outdoor unit.

Flaring

Insert a flare nut into the pipe, and flare the pipe. As the flaring sizes of R410A differ from those of refrigerant R22, the flare tools newly manufactured for R410A are recommended. However, the conventional tools can be used by adjusting projection margin of the copper pipe.

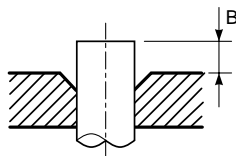

• Projection margin in flaring : B (Unit : mm)

Rigid (Clutch type)

Outer diam. of copper pipe	R410A tool used		Conventional tool used	
	R410A	R22	R410A	R22
6.4 to 15.9	0 to 0.5	(Same as left)	1.0 to 1.5	0.5 to 1.0

Imperial (Wing nut type)

Outer diam. of copper pipe	R410A	R22
6.4 or 9.5	1.5 to 2.0	1.0 to 1.5
12.7 or 15.9	2.0 to 2.5	1.5 to 2.0

• Flaring diam. meter size : A (Unit : mm)

Outer diam. of copper pipe	A $\begin{matrix} +0 \\ -0.4 \end{matrix}$	
	R410A	R22
6.4	9.1	9.0
9.5	13.2	13.0
12.7	16.6	16.2
15.9	19.7	19.2

- * In case of flaring for R410A with the conventional flare tool, pull it out approx. 0.5 mm more than that for R22 to adjust to the specified flare size. The copper pipe gauge is useful for adjusting projection margin size.

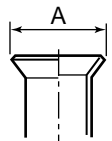

Tightening connection

CAUTION

- Do not apply excessive torque. Otherwise, the nut may crack depending on the conditions.

(Unit : N•m)

Outer diam. of copper pipe	Tightening torque
6.4 mm (diam.)	14 to 18 (1.4 to 1.8 kgf•m)
9.5 mm (diam.)	33 to 42 (3.3 to 4.2 kgf•m)
12.7 mm (diam.)	50 to 62 (5.0 to 6.2 kgf•m)
15.9 mm (diam.)	63 to 77 (6.3 to 7.7 kgf•m)

• Tightening torque of flare pipe connections

Pressure of R410A is higher than that of R22. (Approx. 1.6 times) Therefore, using a torque wrench, tighten the flare pipe connecting sections which connect the indoor and outdoor units of the specified tightening torque. Incorrect connections may cause not only a gas leak, but also a trouble of the refrigeration cycle.

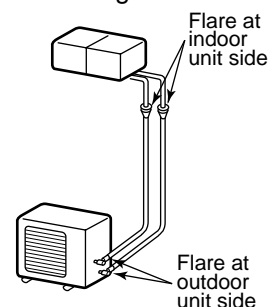

Align the centers of the connecting pipes and tighten the flare nut as far as possible with your fingers. Then tighten the nut with a spanner and torque wrench as shown in the figure.

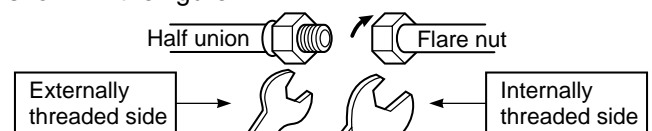

Use a wrench to secure. Use a torque wrench to tighten.

Piping with outdoor unit

- Shape of valve differs according to the outdoor unit. For details of installation, refer to the Installation Manual of the outdoor unit.

Air purge

Using a vacuum pump, perform vacuuming from the charge port of valve of the outdoor unit.

For details, follow to the Installation Manual attached to the outdoor unit.

- Never use the refrigerant sealed in the outdoor unit for air purge.

REQUIREMENT

For the tools such as charge hose, etc., use those manufactured exclusively for R410A.

Refrigerant amount to be added

For addition of the refrigerant, add refrigerant "R410A" referring to the attached Installation Manual of outdoor unit.

Be sure to use a scale to charge the refrigerant of specified amount.

REQUIREMENT

- Charging an excessive or too little amount of refrigerant causes a trouble of the compressor. Be sure to charge the refrigerant of specified amount.
- A personnel who charged the refrigerant should write down the pipe length and the added refrigerant amount in the nameplate attached to the service panel of the outdoor unit. It is necessary to troubleshoot the compressor and refrigeration cycle malfunction.

Open the valve fully

Open the valve of the outdoor unit fully. A 4mm-hexagonal wrench is required for opening the valve.

For details, refer to the Installation Manual attached to the outdoor unit.

Gas leak check

Check with a leak detector or soap water whether gas leaks or not, from the pipe connecting section or cap of the valve.

REQUIREMENT

Use a leak detector manufactured exclusively for HFC refrigerant (R410A, R134a, etc.).

Thermal insulation process

Apply thermal insulation for the pipes separately at liquid side and gas side.

For the thermal insulation to the pipes at gas side, be sure to use the material with heat-resisting temperature 120°C or higher.

Using the attached thermal insulation material, apply the thermal insulation to the pipe connecting section of the indoor unit securely without gap.

REQUIREMENT

Apply the thermal insulation to the pipe connecting section of the indoor unit securely up to the root without exposure of the pipe. (The pipe exposed to the outside causes water leak.)

5 ELECTRICAL WORK

WARNING

1. **Using the specified cables, ensure to connect the wires, and fix wires securely so that the external tension to the cables do not affect the connecting part of the terminals.**

Incomplete connection or fixation may cause a fire, etc.

2. **Be sure to connect earth wire. (Grounding work)**

Do not connect the earth wire to gas pipe, city water pipe, lightning rod, or the earth wire of telephone. Incomplete grounding causes an electric shock.

3. **For electric work, strictly follow the Local Regulation in each country and the Installation Manual, and use an exclusive circuit.**

Capacity shortage of power circuit or incomplete installation may cause an electric shock or a fire.

CAUTIONS

- This indoor unit has no power cord.
- If incorrect/incomplete wiring is carried out, it will cause an electrical fire or smoke.
- Be sure to install an earth leakage breaker that is not tripped by shock waves.
If an earth leakage breaker is not installed, an electric shock may be caused.
- Be sure to use the cord clamps attached to the product.
- Do not damage or scratch the conductive core and inner insulator of power and inter-connecting cables when peeling them.
- Be sure to comply with local regulations on running the wire from outdoor unit to indoor unit (size of wire and wiring method etc.)
- Use the power cord and Inter-connecting cable of specified thickness, type, and protective devices required.

REQUIREMENT

- For power supply wiring, strictly conform to the Local Regulation in each country.
- For wiring of power supply of the outdoor units, follow the Installation Manual of each outdoor unit.
- Never connect 220–240V power to the terminal blocks (A, B, etc.) for control wiring.
(Otherwise, the system will fail.)
- Perform the electric wiring so that it does not come to contact with the high-temperature part of the pipe.
The coating may melt resulting in an accident.
- After connecting cables to the terminal blocks, provide a trap and fix cables with the cable clamp.
- Run the refrigerant piping line and control wiring line in the same line.
- Do not turn on the power of the indoor unit until vacuuming of the refrigerant pipes completes.

Remote controller wiring

2-core non polarity cable is used for the remote controller wiring.

How to wire

1. Connect the connecting cable to the terminal as identified with their respective numbers on the terminal block of indoor and outdoor unit. H07 RN-F or 245 IEC 66 (1.5 mm² or more)
2. Insulate the unsheathed redundant cords (conductors) with electrical insulation tape.
Process them so that they do not touch any electrical or metal parts.
3. For inter-unit wiring, do not use a wire jointed to another on the way.

Cable connection

REQUIREMENT

- Be sure to connect the cables matching the terminal numbers. Incorrect connection causes a trouble.
- Be sure to pass the cables through the bushing of cabling connection port of the indoor unit.
- Keep a margin (Approx. 100mm) on a cable to hang down the electric parts box at servicing, etc.
- The low-voltage circuit is provided for the remote controller. (Do not connect the high-voltage circuit)

- Remove the cover of the electric parts box by taking off the mounting screws (3 positions) and pushing the hooking section. (The cover of the electric parts box remains hanged to the hinge.)
- Connect the indoor/outdoor connection cables and remote controller cable to the terminal block of the electric parts box. (Do not apply tension to the connecting section of the terminal block.)
- Tighten the screws of the terminal block, and fix the cables with cord clamp attached to the electric parts box. (Do not apply tension to the connecting section of the terminal block.)
- Using the attached thermal insulation material, seal the pipe connecting port. Otherwise, dewing may be caused.
- Mount the cover of the electric parts box without pinching cables. (Mount the cover after cabling on the ceiling panel.)

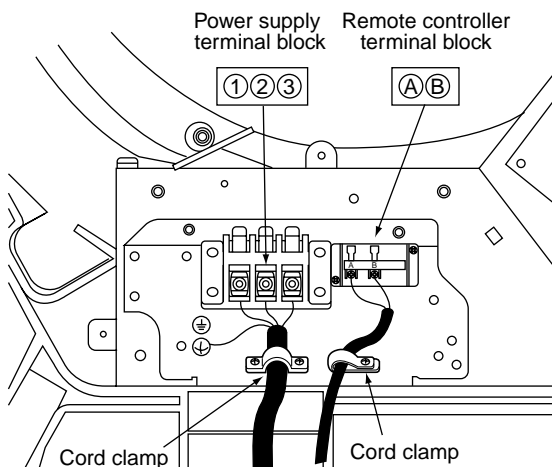
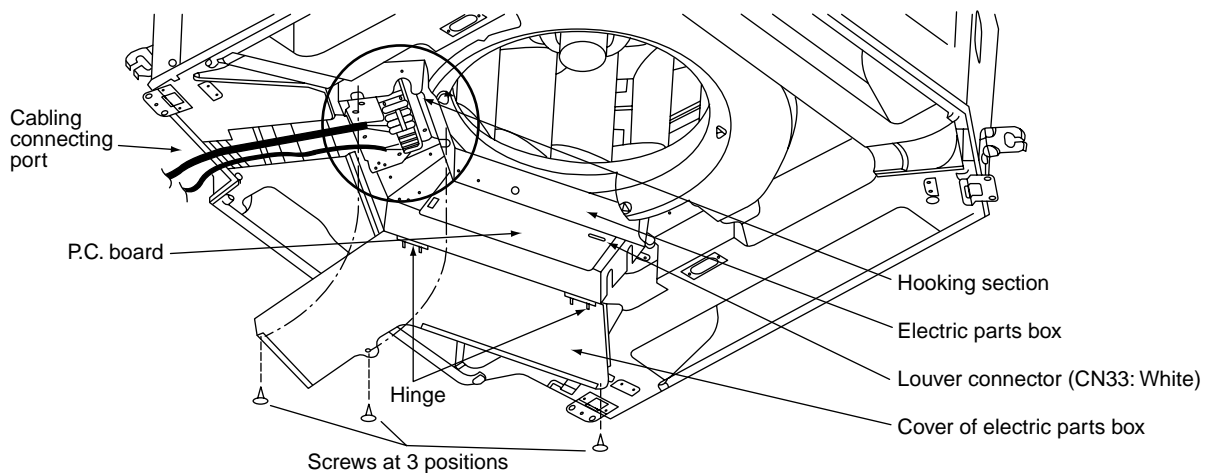

<Thermal insulation to cabling connecting port>

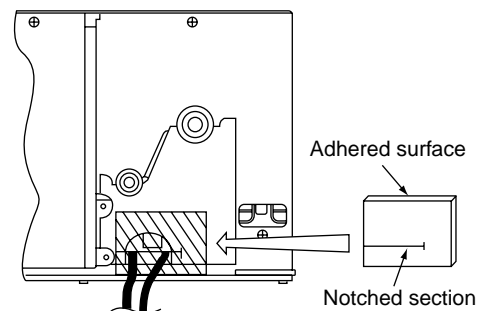

Cabling on the ceiling panel

According to the Installation Manual of the ceiling panel, connect the connector (5P: White) of the ceiling panel to the connector (CN33: White) on P.C. board of the electric parts box.

5 ELECTRICAL WORK

Cabling

1. Remove a screw and then remove cover of the electric parts box.
2. Strip wire ends (10 mm).
3. Match wire colors with terminal numbers on indoor and outdoor units' terminal blocks and firmly screw wires to the corresponding terminals.
4. Connect the ground wires to the corresponding terminals.
5. Fix the cable with cord clamp.
6. Fix cover of the parts box and the terminal block surely with the fixing screws.

Make a loop on the cable for margin of the length so that the electric parts box can be taken out during servicing.

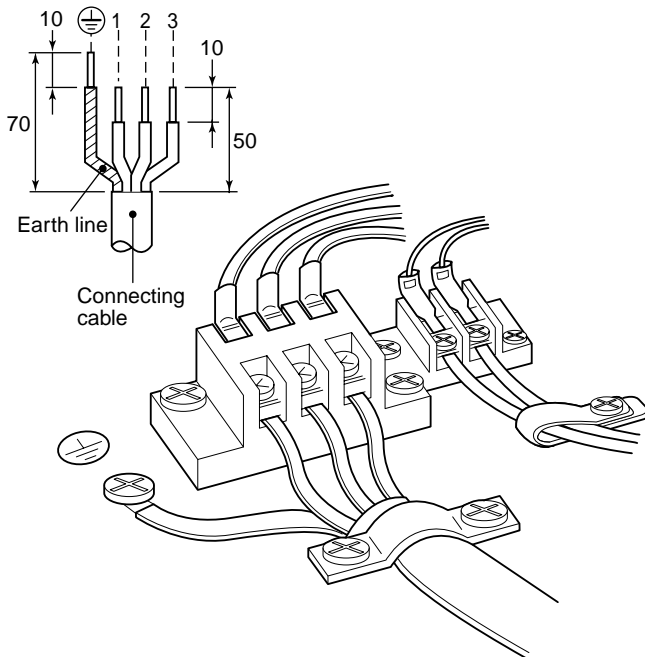

Remote Controller Cabling

- Strip off approx. 9mm the cable to be connected.
- Non polarity, 2 core cable is used for cabling of the remote controller.

Cabling diagram

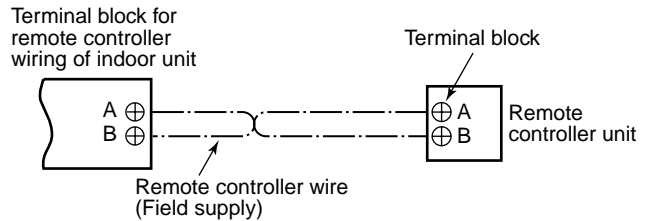

Wiring diagram

<Single system>

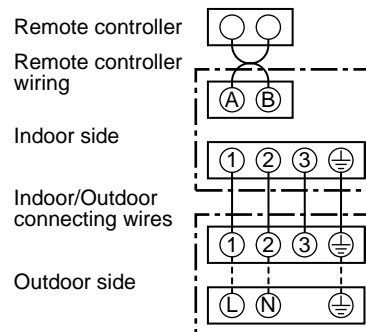

<Synchronous twin system>

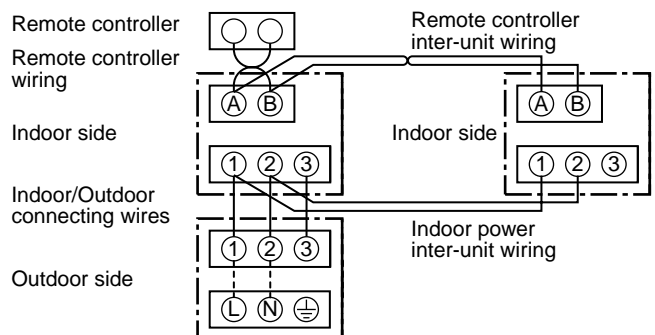

- For details of cabling/installation of the remote controller, refer to the Installation Manual attached to in the remote controller.

6 TEST RUN

Before test run

- Before turning on the power supply, carry out the following procedure.
 - 1) Using 500V-megger, check 1MΩ or more exists between the terminal block 1 to 3 and the earth.
If 1MΩ or less is detected, do not run the unit. Do not apply to the remote controller circuit.
 - 2) Check the valve of the outdoor unit being opened fully.
- To protect the compressor at activation time, leave power-ON for 12 hours or more before operating.

How to execute a test run

Using the remote controller, operate the unit as usual.

For the procedure of the operation, refer to the attached Owner's Manual.

A forced test run can be executed in the following procedure if the operation stops by thermo.-OFF.

In order to prevent a serial operation, the forced test run is released after 60 minutes have passed and returns to the usual operation.

CAUTION



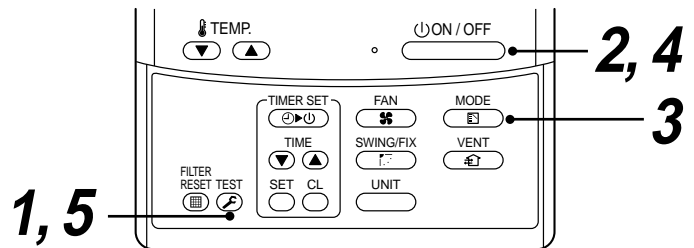

When the remote controller is used for the first time, it accepts an operation approx. 5 minutes after the power supply has been turned on.
It is not a trouble, but is because the setup of the remote controller is being checked.
For the second power-ON time and after, approx. 1 minute is required to start the operation by the remote controller.

NOTE

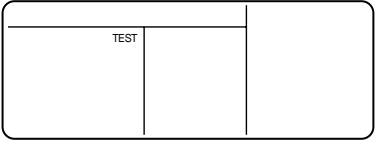
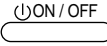

Do not use the forced test run for cases other than the test run because it applies an excessive load to the devices.

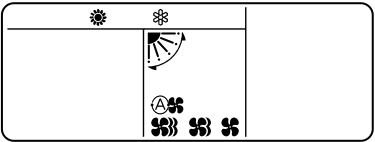
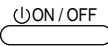

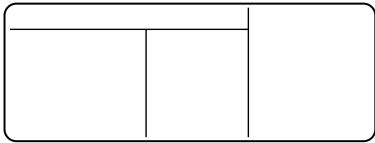
In case of wired remote controller

Procedure	Description
1	Keep  button pushed for 4 seconds or more. [TEST] is displayed on the display part and the selection of mode in the test mode is permitted. 
2	Push  button.
3	Using  button, select the operation mode, [COOL] or [HEAT]. <ul style="list-style-type: none"> • Do not run the air conditioner in a mode other than [COOL] or [HEAT]. • The temperature controlling function does not work during test run. • The detection of error is performed as usual. 
4	After the test run, push  button to stop a test run. (Display part is same as procedure 1 .)
5	Push  check button to cancel (release from) the test run mode. ([TEST] disappears on the display and the status returns to a normal.) 

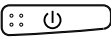
In case of wireless remote controller

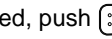
Procedure	Description
1	Turn off the power supply of the air conditioner. Remove the adjust corner cap attached with the sensor part from the ceiling panel. To remove it, refer to Installation Manual attached to the ceiling panel. (Be cautious to treat the sensor part because it is connected with wires.) Remove the sensor cover from the adjust corner cap. (With 1 screw)
2	Change Bit [1: TEST] of switch [S003] on the sensor P.C. board from OFF to ON. Attach the sensor cover, and then the adjust corner cap with sensor part to the ceiling panel. Turn on the main power of the air conditioner.
3	Push  button on the wireless remote controller, and then set the operation mode to [COOL] or [HEAT] by  button. (All the display lamps of the sensors on the wireless remote controller flash during test operation.) <ul style="list-style-type: none"> • Do not use the air conditioner in a mode other than [COOL] or [HEAT] mode. • Error detection is performed as usual.
4	After the test operation has finished, push  button to stop the operation.
5	Turn off the main power of the air conditioner. Return Bit [1] of switch [S003] on the sensor P.C. board from ON to OFF. Attach the adjust corner cap with sensors to the ceiling panel.

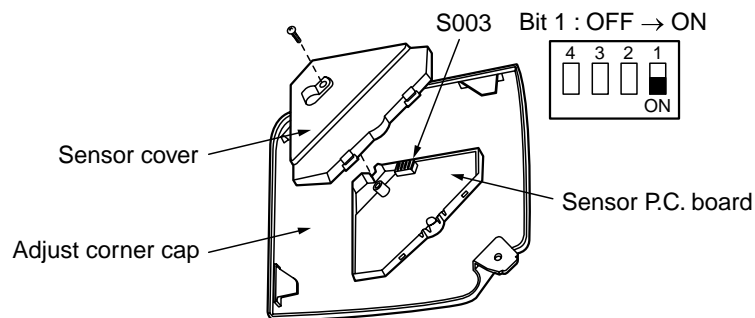

7 APPLICABLE CONTROLS

Change of lighting time of filter sign

According to the installation condition, the lighting time of the filter sign (Notification of filter cleaning) can be changed.

Follow to the basic operation procedure

(**1** → **2** → **3** → **4** → **5** → **6**).

- For the item code in Procedure **3**, specify [01].
- For the [Set data] in Procedure **4**, select the setup data of filter sign lighting time from the following table.

Setup data	Filter sign lighting time
0000	None
0001	150H
0002	2500H (At shipment from factory)
0003	5000H
0004	10000H

To secure better effect of heating

When it is difficult to obtain satisfactory heating due to installation place of the indoor unit or structure of the room, the detection temperature of heating can be raised. Also use a circulator, etc. to circulate heat air near the ceiling.

Follow to the basic operation procedure

(**1** → **2** → **3** → **4** → **5** → **6**).

- For the item code in Procedure **3**, specify [06].
- For the set data in Procedure **4**, select the setup data of shift value of detection temperature to be set up from the table below.

Setup data	Detection temp shift value
0000	No shift
0001	+1°C
0002	+2°C (At shipment from factory)
0003	+3°C
0004	+4°C
0005	+5°C
0006	+6°C

7 APPLICABLE CONTROLS

Group control

Simultaneous twin system

If combining with an outdoor unit, ON/OFF operation of two indoor units is simultaneously available for the twin system.

<Twin system>

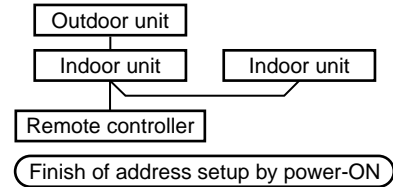

- For wiring procedure and wiring method, follow to the “Electric work” in this manual.
- When the power supply has been turned on, the automatic address setup starts and “ ” display which indicates that address is being set up flashes on the display part. During setup of automatic address, the remote controller operation is not accepted.

Required time up to the finish of automatic addressing is approx. 5 minutes.

In case of group control for system of multiple units

One remote controller can control maximum 8 indoor units as a group.

<In case of group control in single system>

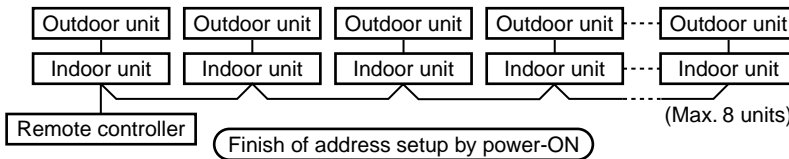

NOTE

In some cases, it is necessary to change the address manually after setup of the automatic address according to the system configuration of the group control.

- For wiring procedure and wiring method of the individual line (Identical refrigerant line) system, follow to “Electric work”.
- Wiring between lines is performed in the following procedure.
Connect the terminal block (A/B) of the indoor unit connected with a remote controller to the terminal blocks (A/B) of the indoor units of other indoor units by wiring the inter-unit wire of the remote controller.
- When the power supply has been turned on, the automatic address setup starts and “ ” display which indicates that address is being set up flashes on the display part. During setup of automatic address, the remote controller operation is not accepted.

Required time up to the finish of automatic addressing is approx. 5 minutes.

(Example) Group control for complex system

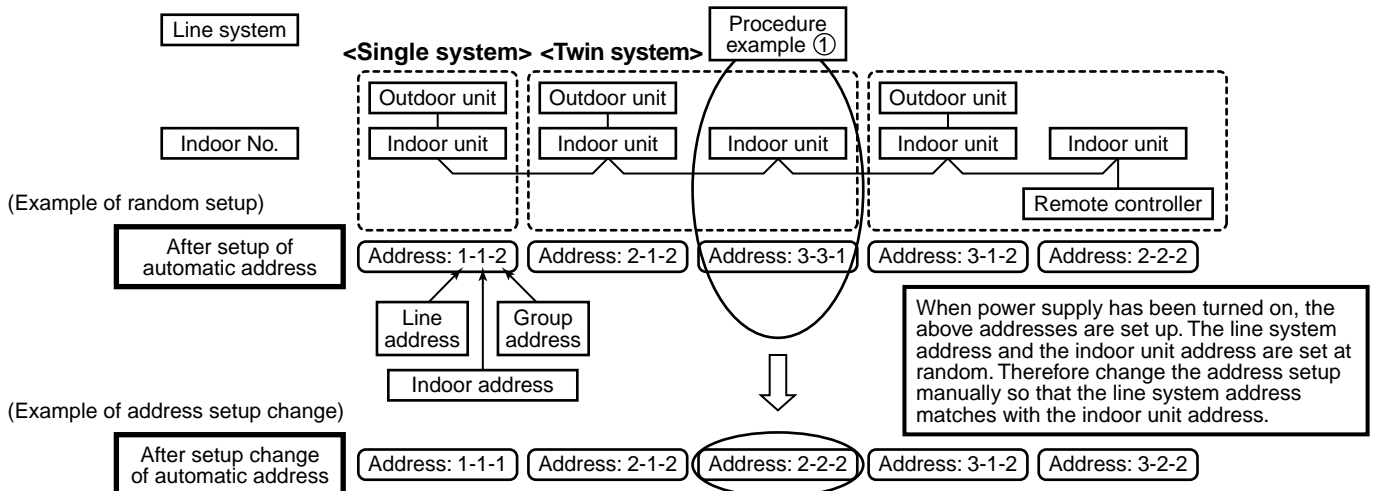





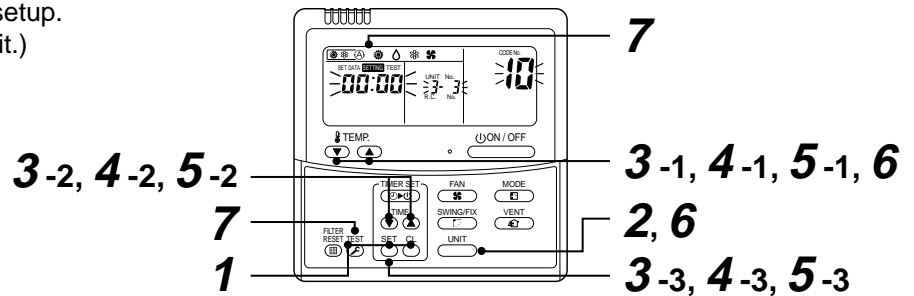



Procedure example ① Manual address setup procedure

While the operation stops, change the setup.
(Be sure to stop the operation of the unit.)

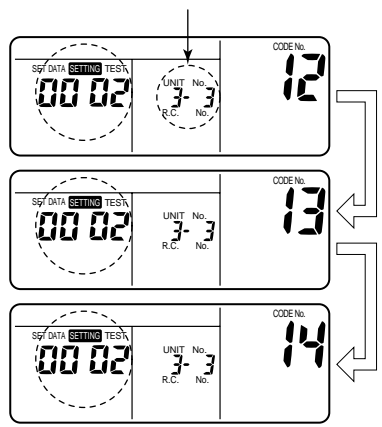

Procedure	Description
1	<p>Push simultaneously SET + CL + TEST buttons for 4 seconds or more. After a while, the display part flashes as shown below. Check the displayed ITEM CODE is [10].</p> <ul style="list-style-type: none"> When the ITEM CODE is other than [10], push TEST button to erase the display and repeat procedure from the first step. (After pushing TEST button, operation of the remote controller is not accepted for approx. 1 minute.) (For a group control, No. of the firstly displayed indoor unit becomes the header unit.)
2	<p>Every pushing UNIT button, the indoor unit No. in the group control is displayed in order. Select the indoor unit of which setup is changed.</p> <p>In this time, the position of the indoor unit of which setup is changed can be confirmed because fan and flap of the selected indoor unit operate.</p>
3-1	<p>Using temp. setup ▼ / ▲ buttons, specify ITEM CODE [12]. (ITEM CODE [12]: Line address)</p> <p style="text-align: right;">Indoor unit No. before setup change is displayed.</p>
3-2	<p>Using timer time ▼ / ▲ buttons, change the line address from [3] to [2].</p>
3-3	<p>Push SET button.</p> <p>In this time, the setup finishes when the display changes from flashing to lighting.</p>
4-1	<p>Using temp. setup ▼ / ▲ buttons, specify ITEM CODE [13]. (ITEM CODE [13]: Indoor address)</p> <p style="text-align: right;">Indoor unit No. before setup change is displayed.</p>
4-2	<p>Using timer time ▼ / ▲ buttons, change the indoor address from [3] to [2].</p>
4-3	<p>Push SET button.</p> <p>In this time, the setup finishes when the display changes from flashing to lighting.</p>
5-1	<p>Using temp. setup ▼ / ▲ buttons, specify ITEM CODE [14]. (ITEM CODE [14]: Group address)</p> <p style="text-align: right;">Indoor unit No. before setup change is displayed.</p>
5-2	<p>Using timer time ▼ / ▲ buttons, change the setup data from [0001] to [0002]. (Setup data [Header unit: 0001] [Follower unit: 0002])</p>
5-3	<p>Push SET button.</p> <p>In this time, the setup finishes when the display changes from flashing to lighting.</p>







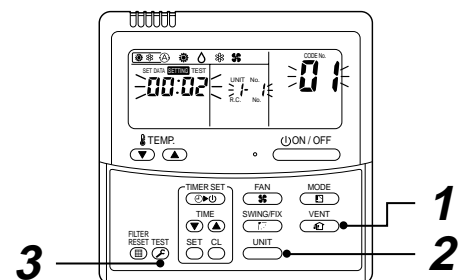

7 APPLICABLE CONTROLS

Procedure	Description
<p>6</p> <p>If there is other indoor unit to be changed, repeat procedure 2 to 5 to change the setup.</p> <p>When the above setup has finished, push  to select the indoor unit No. before change of setup, specify ITEM CODE [12], [13], [14] in order with temp. setup  /  buttons, and then check the changed contents.</p> <p>Address change check Before change: [3-3-1] → After change: [2-2-2]</p> <p>Pushing CL button clears the contents of which setup was changed. (In this case, procedure from 2 is repeated.)</p>	<p>Indoor unit No. before setup change is displayed.</p> 
<p>7</p> <p>After check of the changed contents, push  button. (Setup is determined.) When pushing  button, the display disappears and the status becomes the usual stop status. (When pushing  button the operation from the remote controller is not accepted for approx. 1 minute.)</p> <p>* If the operation from the remote controller is not accepted even 1 minute or more passed after pushing  button, it is considered that the address setup is incorrect. In this case, the automatic address must be again set up. Therefore repeat procedure of the setup change from the Procedure 1.</p>	

To recognize the position of the corresponding indoor unit though the indoor unit No. is known

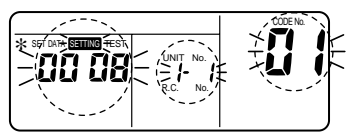
Check the position during operation stop.
(Be sure to stop operation of the set.)

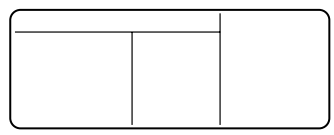

Procedure	Description
<p>1</p> <p>Push simultaneously  +  buttons for 4 seconds or more. After a while, the display part flashes and the display appears as shown below. In this time, the position can be checked because fan and flap of the indoor unit operate.</p> <ul style="list-style-type: none"> For the group control, the indoor unit No. is displayed as [ALL] and fans and flaps of all the indoor units in the group control operate. <p>Check the displayed ITEM CODE is [01].</p> <ul style="list-style-type: none"> When the ITEM CODE is other than [01], push  button to erase the display and repeat procedure from the first step. (After pushing  button, operation of the remote controller is not accepted for approx. 1 minute.) 	 <p>(* Display changes according to the model No. of indoor unit.)</p>
<p>2</p> <p>In the group control, every pushing  button, the indoor unit No. in the group control is displayed in order. In this time, the position of the indoor unit can be confirmed because only fan and flap of the selected indoor unit operate. (For a group control, No. of the firstly displayed indoor unit becomes the header unit.)</p>	
<p>3</p> <p>After confirmation, push  button to return the mode to the usual mode.</p> <p>When pushing  button, the display disappears and the status becomes the usual stop status. (When pushing  button the operation from the remote controller is not accepted for approx. 1 minute.)</p>	

8 TROUBLESHOOTING

Confirmation and check

When a trouble occurred in the air conditioner, the check code and the indoor unit No. appear on the display part of the remote controller.

The check code is only displayed during the operation.

If the display disappears, operate the air conditioner according to the following "Confirmation of error history" for confirmation.

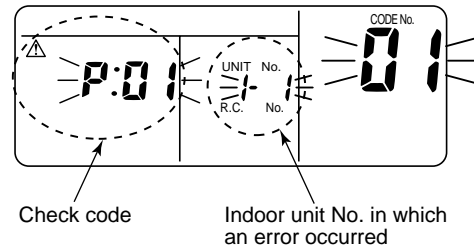

Confirmation of error history

When a trouble occurred on the air conditioner, the trouble history can be confirmed with the following procedure. (The trouble history is stored in memory up to 4 troubles.)

The history can be confirmed from both operating status and stop status.

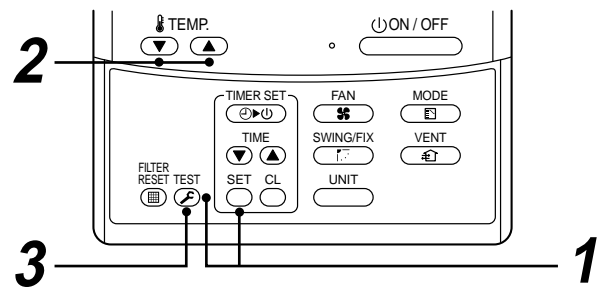

Procedure	Description
1	<p>When pushing SET and TEST buttons at the same time for 4 seconds or more, the following display appears.</p> <p>If [Service check] is displayed, the mode enters in the trouble history mode.</p> <ul style="list-style-type: none"> • [01 : Order of trouble history] is displayed in CODE No. window. • [Check code] is displayed in CHECK window. • [Indoor unit address in which an error occurred] is displayed in UNIT No.
2	<p>Every pushing of [TEMP.] button used to set temperature, the trouble history stored in memory is displayed in order.</p> <p>The numbers in CODE No. indicate CODE No. [01] (latest) → [04] (oldest).</p> <p>REQUIREMENT</p> <p>Do not push CL button because all the trouble history of the indoor unit will be deleted.</p>
3	<p>After confirmation, push TEST button to return to the usual display.</p>

1. Check the troubles according to the above procedure.
2. Ask an authorized dealer or qualified service (maintenance) professional to repair or maintain the air conditioner.
3. More details of the service code are explained in Service Manual.

9 MAINTENANCE

Before maintenance, be sure to turn off the leakage breaker.

Cleaning of air filter

- If  is displayed on the remote controller, maintain the air filter.
- Clogging of the air filter reduce cooling/heating performance.

Cleaning of panel and air filter

Preparation :

1. Turn off the air conditioner by the remote controller.
2. Open the suction air port.
 - Slide the button of the suction air port inward, and open the suction port slowly while holding it.

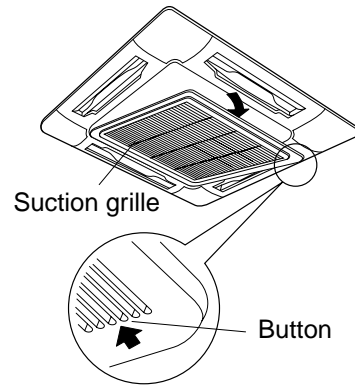

Clean the panel and air filter with water:

- Wipe down the panel and air filter with a sponge or towel moistened with a kitchen detergent. (Do not use any metallic brush for cleaning.)
 - **Carefully rinse the panel and air filter to wash out the detergent.**
 - **After rinsing the panel and air filter with water, dry it in the shade.**
3. Close the suction air port.
 - Close the suction air port, slide the button outward, and fix the suction port securely.

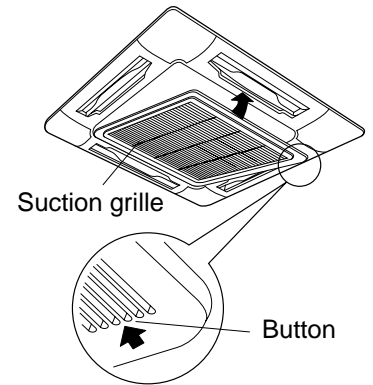

CAUTION

- Do not start the air conditioner while leaving the panel and air filter removed.
- Push the filter reset button. ( indication will be turn off.)

Cleaning of Air Filters

- If the air filters are not cleaned, it not only reduce the cooling a performance of air conditioner but causes a failure in the air conditioner such as water falling in drops.

Preparation :

1. Stop the operation by remote controller.
2. Dismount the air filter.

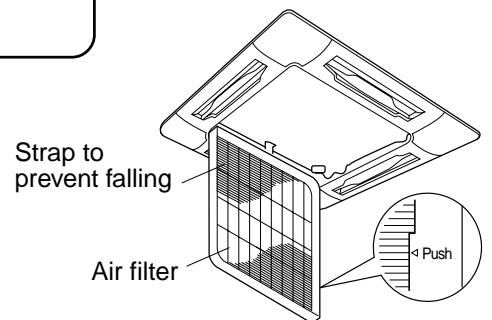

Use a vacuum cleaner to remove dust from the filters or wash them with water.

- After rinsing the air filters with water, dry them in the shade.
- Set the air filter into the air conditioner.

Cleaning of discharge flap

The discharge flap can be removed to clean.

1. Remove the discharge flap.
 - Holding the both ends of the discharge flap, remove the flap sagging the center downward.
2. Cleaning with water
 - If the dirt is terrible, clean the flap by tepid water with neutral detergent or water.
3. Mount the discharge flap.
 - First push in one side of the flap, and then insert the other side sagging the center downward.

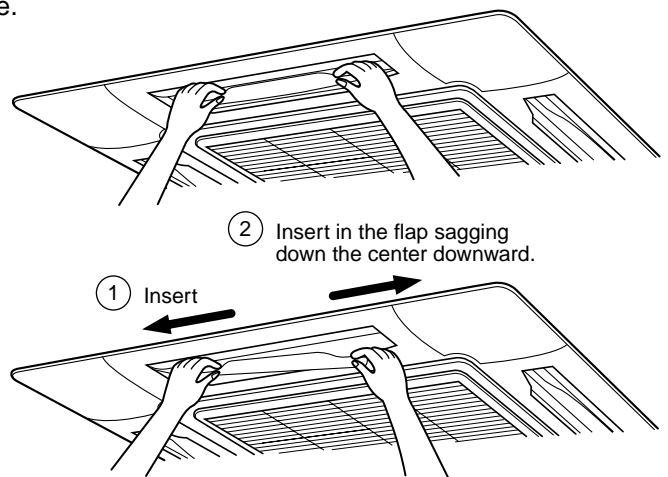

Be careful to the direction of the flap when mounting.

Mount the flap so that the side with the mark faces upward and the arrow direction of the mark directs.

This product is compliant with Directive 2002/95/EC, and cannot be disposed as unsorted municipal waste.

Ce produit est conforme à la Directive 2002/95/CE et il ne peut pas être jeté avec les ordures ménagères non triées.

Dieses Produkt entspricht der Richtlinie 2002/95/EWG und darf nicht als normaler, unsortierter Hausabfall entsorgt werden.

Questo prodotto è conforme alla direttiva 2002/95/CE, e per disfarsene non deve essere gettato con la spazzatura della casa.

Este producto cumple con la Directiva 2002/95/EC, y no se puede desechar como la basura municipal.

Este produto respeita a Directiva 2002/95/EC e não pode ser deitado fora como lixo municipal.

Dit product is in overeenstemming met richtlijn 2002/95/EC en mag niet als huishoudelijk afval worden afgevoerd.

Το προϊόν αυτό συμμορφώνεται με την Οδηγία 2002/95/ΕΕ και δεν μπορεί να απορριφτεί ως μη ταξινομημένο δημοτικό απόβλητο.